



RECON

A Company of Specialists

RESPECT
INTEGRITY
TRUST

Since 1972

www.recon-us.com





EARIP Adaptive Management Program Discussion

Paul Fromer

RECON Environmental

November 11, 2010



AMP Governance

EARIP HCP Adaptive Management Program Governance Structure

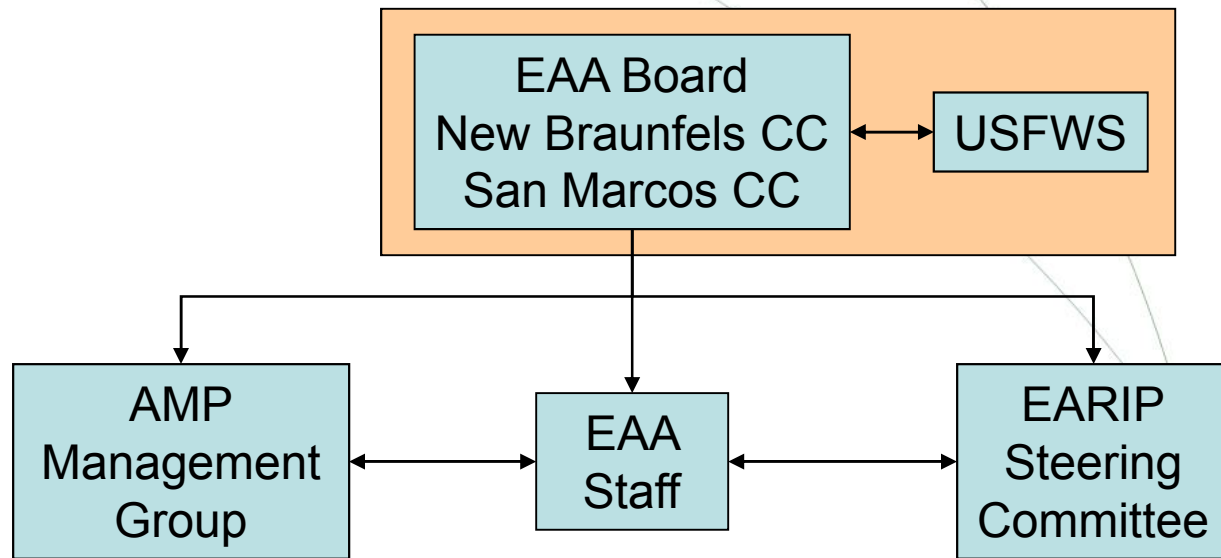

- New Braunfels
- San Marcos
- TSUSM
- USFWS
- TPW
- Other Managers

(my original structure)

EARIP HCP Permit Compliance Structure

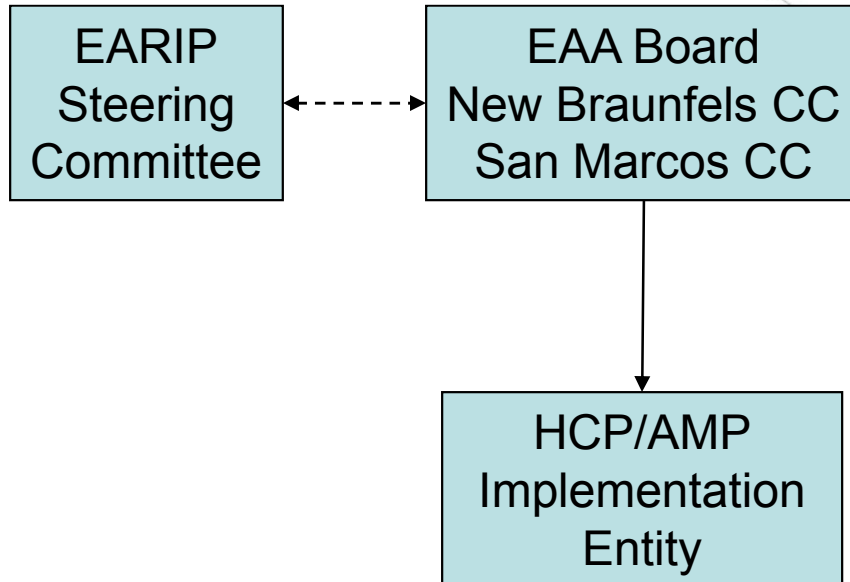

EARIP HCP Decision Structure

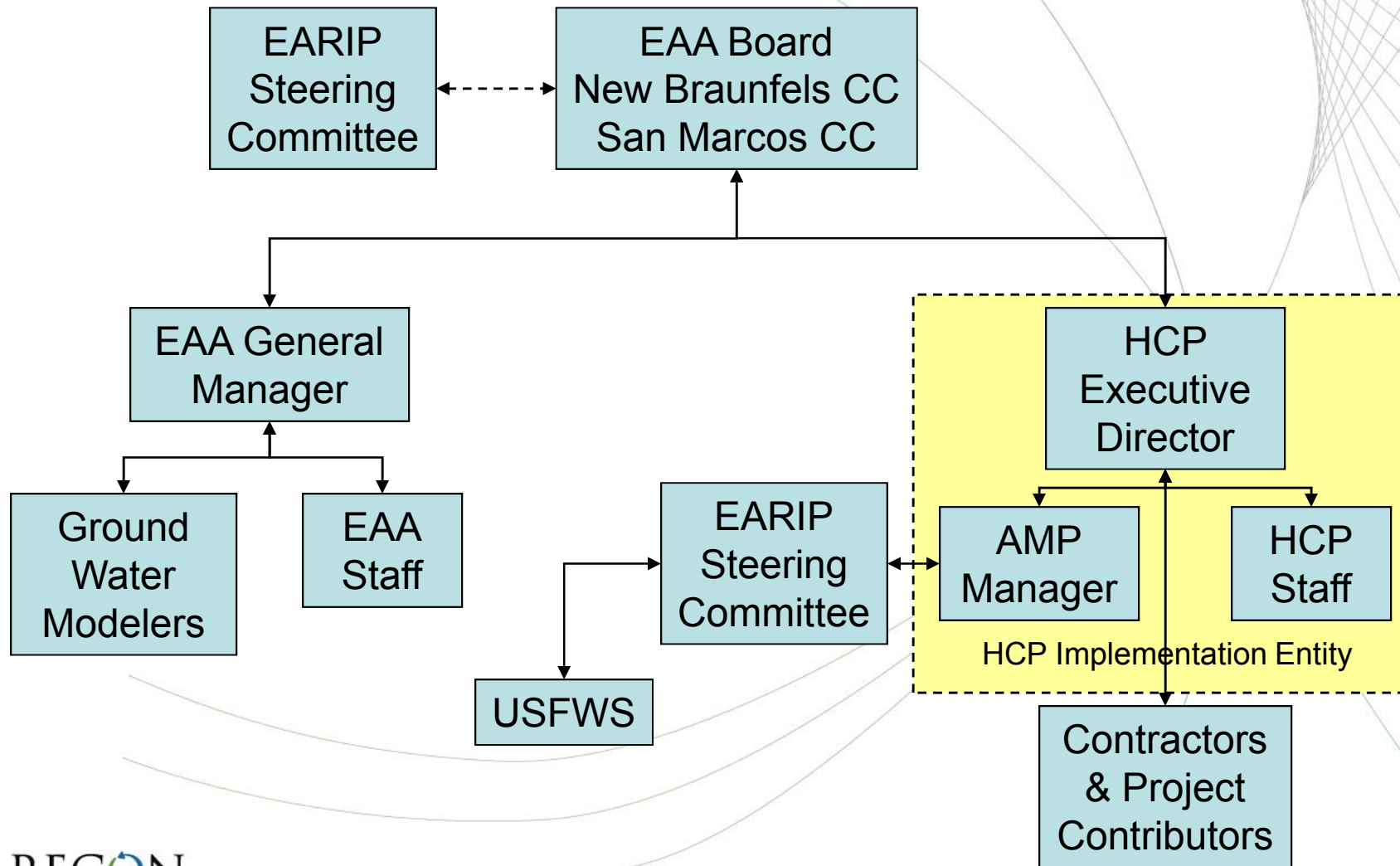

EARIP HCP Adaptive Management Program Governance Roles

- EAA Board, New Braunfels CC, San Marcos CC
 - Primary Permit holders
 - Responsible for implementation of terms and conditions of the Implementing Agreement
- HCP Implementation Agency
 - Implementation of mitigation measures
 - Monitoring
 - Reporting, including proposed revisions
 - Budget recommendations to Board and CCs

EARIP HCP Adaptive Management Program Governance Roles

- EARIP Steering Committee
 - Decisions on new/deferred Adaptive Management Measures in HCP
 - Advice to Board and CCs